

THIS LIFTING LUG FITTED ONLY WHEN MOTOR IS VERTICALLY MOUNTED.

NOTE!
CABLE ENTRY CAN BE SUPPLIED IN ANY ONE OF FOUR POSITIONS AT 90° INTERVALS.

NOTE!
STANDARD MACHINES ARE ARRANGED FOR HORIZONTAL OVERHUNG MOUNTING. CUSTOMERS SHOULD NOTIFY US WHEN ORDERING IF VERTICAL MOUNTING IS REQUIRED. IF VERTICAL, THE MOTOR THRUST BEARING MUST NOT BE ALLOWED TO TAKE ANY LOAD OTHER THAN THE WEIGHT OF THE ROTOR WITHOUT OUR APPROVAL.

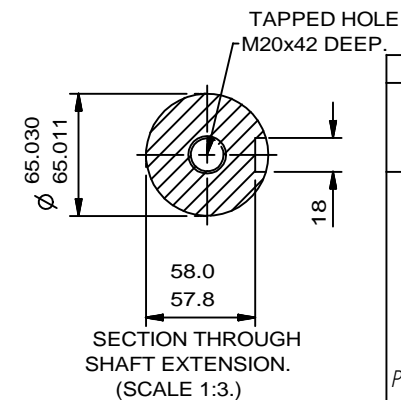

SECTION THROUGH SHAFT EXTENSION. (SCALE 1:3.)

ALL DIMENSIONS IN MILLIMETRES

FIRST ANGLE PROJECTION

BROOK CROMPTON

Produced by **Tamel S.A.** a company of **ATB**

DRG. No.	M9128		
DRG. REF.			
REVISION:		DATE	

TITLE
OUTLINE DIMENSIONS OF STANDARD FLANGE MOUNTED METRIC A.C. MOTOR. TOTALLY ENCLOSED FAN VENTILATED. FRAME SIZE: W-DF280S-D (2 POLE ONLY.)

NOTE!
2.5 ENDPLAY WILL BE PROVIDED FOR ENDTHRUST PROTECTION WHEN CUSTOMERS NOTIFY US OF THEIR INTENTION TO USE RIGID COUPLINGS AND DRIVEN MACHINES WITHOUT ENDPLAY.

	NAME	DATE
DRAWN	JM	18-10-10
CHECKED	KC	18-10-10
SCALE	1:7	

SHEET SIZE
A3