

NOTE!
CABLE ENTRY CAN BE SUPPLIED
IN ANY ONE OF FOUR POSITIONS
AT 90° INTERVALS.

NOTE!
STANDARD MACHINES ARE ARRANGED FOR HORIZONTAL OVERHUNG MOUNTING.
CUSTOMERS SHOULD NOTIFY US WHEN ORDERING IF VERTICAL MOUNTING
IS REQUIRED. IF VERTICAL, THE MOTOR THRUST BEARING MUST NOT BE
ALLOWED TO TAKE ANY LOAD OTHER THAN THE WEIGHT OF THE ROTOR
WITHOUT OUR APPROVAL.

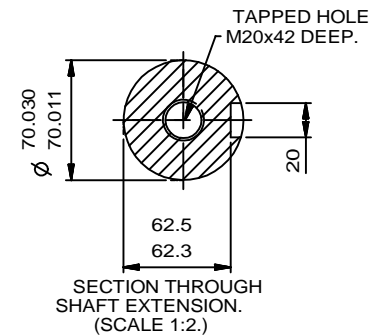

ALL DIMENSIONS IN MILLIMETRES

FIRST ANGLE
PROJECTION

**BROOK
CROMPTON**

Produced by *Tamel s.p.a.* a company of **ATB**
Technology in Motion

SHEET
SIZE

A3

NOTE!
2.5 ENDPLAY WILL BE PROVIDED FOR ENDTHRUST
PROTECTION WHEN CUSTOMERS NOTIFY US OF THEIR
INTENTION TO USE RIGID COUPLINGS AND DRIVEN
MACHINES WITHOUT ENDPLAY.

TITLE

OUTLINE DIMENSIONS OF STANDARD FLANGE MOUNTED METRIC
A.C. MOTOR. TOTALLY ENCLOSED FAN VENTILATED.
FRAME SIZE: W-DF250S-D (4 POLE UP.)

	NAME	DATE
DRAWN	JM	19-10-10
CHECKED	KC	19-10-10
SCALE	1:7	

DRG. No.	M8669		
DRG. REF.			
REVISION:		DATE	