

THIS LIFTING LUG FITTED ONLY WHEN MOTOR IS VERTICALLY MOUNTED.

8 HOLES Ø 19 EQUALLY SPACED ON 500 P.C.D.

NOTE!
CABLE ENTRY CAN BE SUPPLIED IN ANY ONE OF FOUR POSITIONS AT 90 ° INTERVALS.

NOTE!
STANDARD MACHINES ARE ARRANGED FOR HORIZONTAL OVERHUNG MOUNTING. CUSTOMERS SHOULD NOTIFY US WHEN ORDERING IF VERTICAL MOUNTING IS REQUIRED. IF VERTICAL, THE MOTOR THRUST BEARING MUST NOT BE ALLOWED TO TAKE ANY LOAD OTHER THAN THE WEIGHT OF THE ROTOR WITHOUT OUR APPROVAL.

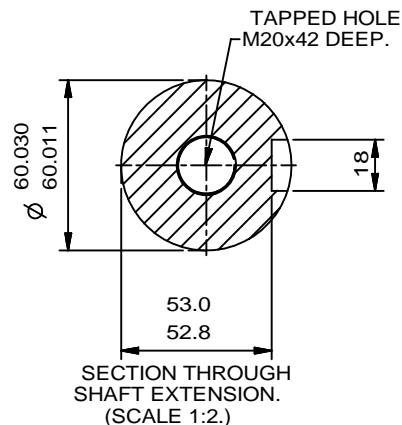

ALL DIMENSIONS IN MILLIMETRES

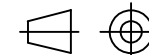

FIRST ANGLE PROJECTION

BROOK CROMPTON

Produced by **Tamel s.a.** a company of **NTB** Technology in Motion

SHEET SIZE A3	NOTE! 2.5 ENDPLAY WILL BE PROVIDED FOR ENDTHRUST PROTECTION WHEN CUSTOMERS NOTIFY US OF THEIR INTENTION TO USE RIGID COUPLINGS AND DRIVEN MACHINES WITHOUT ENDPLAY.
	TITLE OUTLINE DIMENSIONS OF STANDARD FLANGE MOUNTED METRIC A.C. MOTOR. TOTALLY ENCLOSED FAN VENTILATED. FRAME SIZE: W-DF250M-D (2 POLE ONLY.)

NAME	DATE
DRAWN JM	18-10-10
CHECKED KC	18-10-10
SCALE	1:8

DRG. No.	M8713
DRG. REF.	
REVISION:	DATE