

2 LIFTING LUGS
DIAGONALLY
OPPOSITE.

R270

4 HOLES FOR
M16 BOLTS.

TAPPED HOLE
M20x42 DEEP.

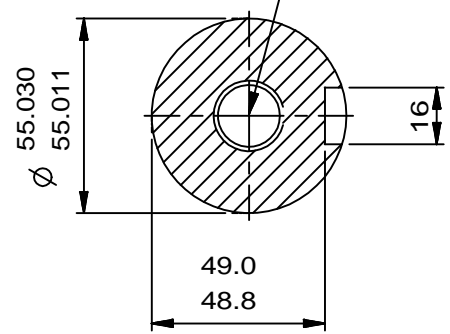
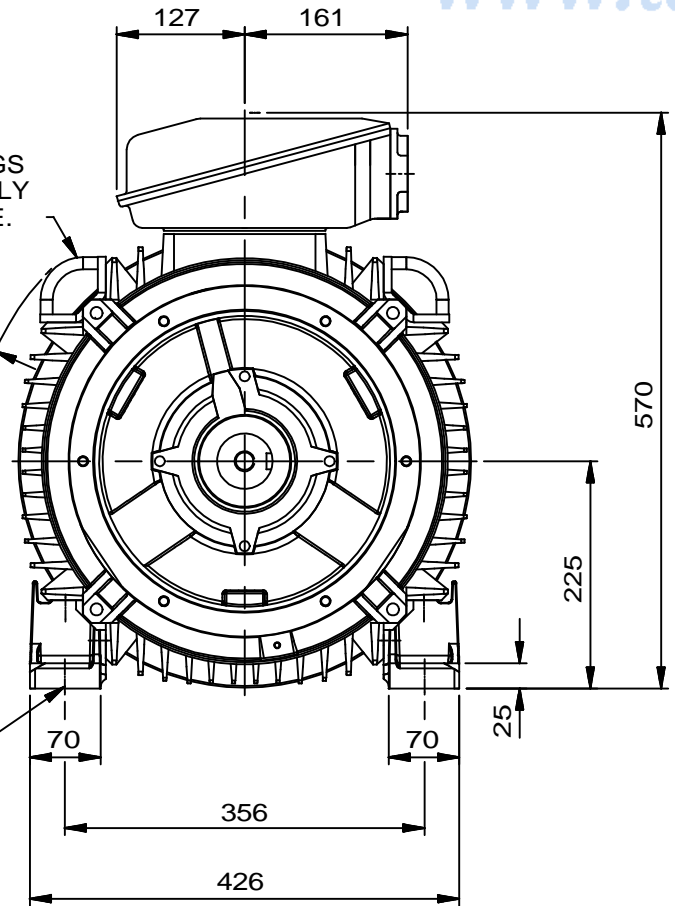

SECTION THROUGH
SHAFT EXTENSION.
(SCALE 1:2.)

NOTE:
TERMINAL BOX CAN BE MOUNTED
(LEFT OR RIGHT) BY REFITTING FEET
AND LIFTING LUGS 90° IN APPROPRIATE
DIRECTIONS. CABLE ENTRY CAN BE
SUPPLIED IN ANY ONE OF FOUR
POSITIONS AT 90° INTERVALS.

ALL DIMENSIONS IN MILLIMETRES

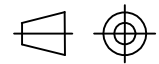

FIRST ANGLE
PROJECTION

**BROOK
CROMPTON**

Produced by **Tamel s.a.** a company of **ATB**
Technology in Motion

SHEET SIZE A3	NOTE! 2.5 ENDPLAY WILL BE PROVIDED FOR ENDTHRUST PROTECTION WHEN CUSTOMERS NOTIFY US OF THEIR INTENTION TO USE RIGID COUPLINGS AND DRIVEN MACHINES WITHOUT ENDPLAY.
	TITLE OUTLINE DIMENSIONS OF STANDARD FOOT METRIC A.C. MOTOR. TOTALLY ENCLOSED FAN VENTILATED. FRAME SIZE: W-DF225M (2 POLE ONLY.)

NAME	DATE
DRAWN JM	06-09-10
CHECKED KC	06-09-10
SCALE	1:7

DRG. No.	M8705		
DRG. REF.			
REVISION:		DATE	